

# HDMI TFT Module Specification

Distributed by:





**MODEL: HB-043WISBIAA1-B**

<◆> PRELIMINARY SPECIFICATION

<◇> APPROVAL SPECIFICATION

<b>CUSTOMER</b>
<b>APPROVED BY</b>
<b>DATE:</b>

DESIGNED	CHECKED	APPROVED
		

DigiWise International Corporation  
 3F., No. 10, Ln 83, Sec 1, Guang Fu Rd., Sanchong Dist., 24158,  
 New Taipei City, Taiwan (ROC)

TEL : +886-2-29992866

FAX : +886-2-29990900



## RECORD OF REVISION

Version	Revised Date	Page	Content
V1.0	2019/07/17	--	First Issued

## TABLE OF CONTENTS

No.	Content	Page
	HDMI TFT Module Specification .....	1
	TABLE OF CONTENTS .....	3
1.	GENERAL DESCRIPTION .....	4
2.	MECHANICAL SPECIFICATION .....	5
3.	PIN DESCRIPTION .....	6
4.	ABSOLUTE MAXIMUM RATINGS .....	7
5.	BLOCK DIAGRAM .....	8
6.	ELECTRICAL CHARACTERISTICS .....	9
7.	PROJECTED CAPACITIVE TOUCH PANEL SPECIFICATION.....	10
8.	OPTICAL CHARACTERISTICS .....	16
9.	RELIABILITY.....	19
10.	PRECAUTION RELATING PRODUCT HANDLING .....	24

## 1. GENERAL DESCRIPTION

### 1.1 Description

HB-043WISBIAA1-B is a 4.3 (16:9) inch diagonally measured active display with high resolution WXGA 800x480 display and high brightness. This model is composed of a TFT LCD panel, backlight system, a projected capacitive touch panel and HDMI interface . It is designed to make Raspberry Pi usage easy. You can simply use this TFT display with your Raspberry Pi, or also you can use this as computer display with any device which has HDMI output. This 4.3" TFT model comes in 800x480 resolution that would be great for embedded computing usage too.

### 1.2 Features:

No.	Item	Specification	Unit
1	Panel Size	4.3"	Inch
2	Number of Pixels	800 (W) x RGB x 480 (H)	Pixels
3	Active Area	95.04 (W) × 53.856 (H)	mm
4	Pixel Pitch	0.1188 (W) x 0.1122 (H)	mm
5	Outline Dimension	105.5 (W) × 67.2 (H) × 18.6 (T)	mm
6	Number of Colors	16.7M	- -
7	Display Mode	IPS / Normally Black / Transmissive	- -
8	View Direction	Free direction	- -
9	Display Format	RGB vertical stripe	- -
10	Surface Treatment	Clear (7H)	- -
11	Contrast Ratio	800 (Typ.)	- -
12	Luminance (cd/m <sup>2</sup> )	1000 (Typ.)	cd/m <sup>2</sup>
13	Video Input Interface	HDMI (Compliance HDMI V1.4 and include HDCP decryption)	- -
14	Backlight	White LED	- -
15	Operation Temperature	-30 ~ 70	°C
16	Storage Temperature	-30 ~ 80	°C
17	Weight	95(Max.)	g



### 3. PIN DESCRIPTION

#### 3.1 HDMI (CN1)

[HDMI A TYPE: A111974-2-01-R or compatible]

Pin No.	Symbol	I/O	Function	Note
1	TMDS 2+	I	TMDS Data2+	
2	GND	P	TMDS Data2 Shield	
3	TMDS 2-	I	TMDS Data2-	
4	TMDS 1+	I	TMDS Data1+	
5	GND	P	TMDS Data1 Shield	
6	TMDS 1-	I	TMDS Data1-	
7	TMDS 0+	I	TMDS Data0+	
8	GND	P	TMDS Data0 Shield	
9	TMDS 0-	I	TMDS Data0-	
10	TMDS CLK+	I	TMDS Clock+	
11	GND	P	TMDS Clock Shield	
12	TMDS CLK-	I	TMDS Clock-	
13	CEC	I	CEC	
14	N.C.	-	N.C.	
15	DDC_SCL	I	IIC SCL to EDID ROM	
16	DDC_SDA	I/O	IIC SDA to EDID ROM	
17	GND	P	DDC/CEC Ground	
18	HD_5V	P	+5V Power	
19	HPD	O	Hot Plug Detect	

#### 3.2 Power Input(CN2)

[WAFER P2.0mm:2001S-02-RTE or compatible]

Pin No.	Symbol	I/O	Function	Note
1	5.0V	P	Power Supply +5V	
2	GND	P	Ground	

#### 3.3 Back-light Control(CN3)

[WAFER P1.25mm: 1251-03-ST-SE or compatible]

Pin No.	Symbol	I/O	Function	Note
1	GND	P	Ground	
2	PWM	I	Back-light Dimming control (internal pull up to 3.3V)	*1
3	NC	-	No connection.	

**4. ABSOLUTE MAXIMUM RATINGS**

**4.2 Electrical Absolute Rating**

**4.2.1 HDMI TFT LCD Module**

Item	Symbol	Values		Unit	Note
		Min	Max.		
Power supply voltage	5.0V	4.5	5.5	V	

**4.2.2 Environment Absolute Rating**

Item	Symbol	Values			Unit	Note
		Min	Typ	Max.		
Operating Temperature	Top	-30	-	70	°C	Ambient temperature
Storage Temperature	Tst	-30	-	80	°C	

5. BLOCK DIAGRAM

5.2 TFT LCD Module

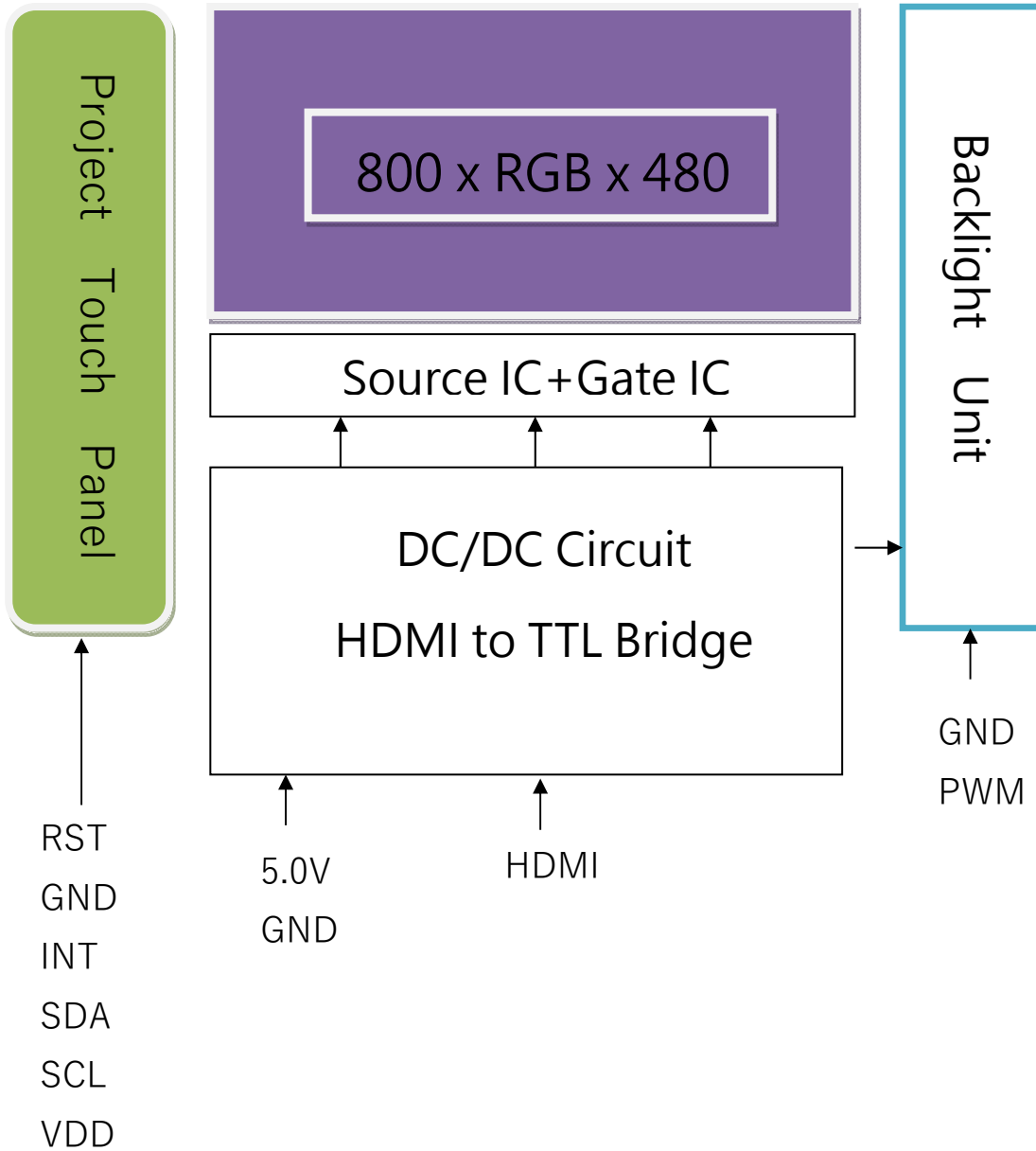

## 6. ELECTRICAL CHARACTERISTICS

### 6.2 HDMI TFT LCD Module

Item	Symbol	Values			Unit	Note
		Min	Typ.	Max.		
Supply Voltage	5.0V	4.5	5	5.5	V	
PWM frequency		200	-	200K	Hz	
PWM Dimming Voltage	V <sub>PWM-IH</sub>	2	3.3	5	V	
	V <sub>PWM-IL</sub>	-	-	0.8	V	
Supply Current	ICC(5V)	-	375	405	mA	
LED life time		-	50000	-	Hr	(1)

Note 1:

The “LED life time” is defined as the module brightness decrease to 50% original brightness that the ambient temperature is 25°C 60% RH.

## 7. PROJECTED CAPACITIVE TOUCH PANEL SPECIFICATION

### 7.1 Main Feature

Item	Specification	Unit
Screen Size	4.3 inch	Diagonal
Type	Transparent Type Projected Capacitive	--
Input Mode	Human's Finger	--
Finger	5	--
Interface	I2C	--
Cover glass pencil-hardness	7H	--
Response time	25	ms
Driver IC	FT5426	

### 7.3 Pin Assignments and Definitions(CN4) [WAFER P1.25mm: 1251-06-ST-SE or compatible]

Item	Name	I/O	Unit
1	RST	I	Reset, Active low
2	GND	P	Power ground
3	INT	O	Interrupt, Active low
4	SDA	I/O	Serial data
5	SCL	I	Serial Clock
6	VDD	P	Power; VDD =3.3V(typ.)

### 7.4 ELECTRICAL CHARACTERISTICS

Communication protocol: I2C

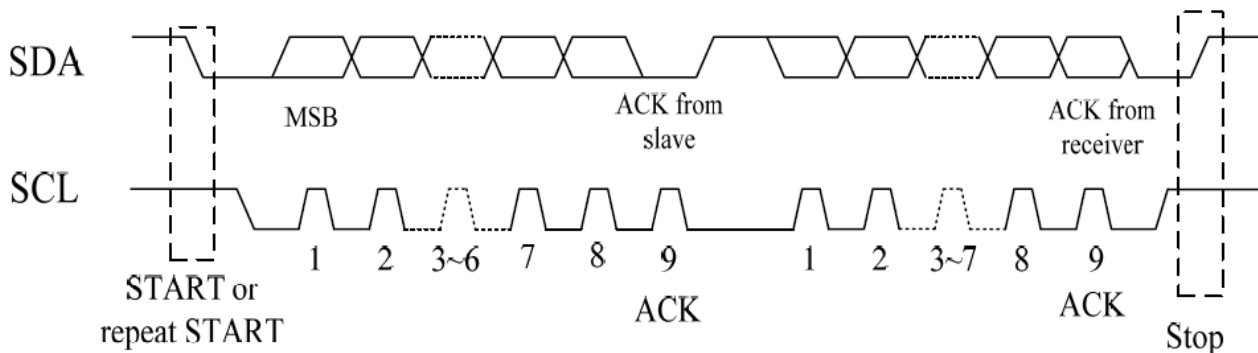

## 7.5 Interface and Data Format

### 7.5.1 Default I2C Address

The default I2C Address of FT5426 is 0x70 (8-bit address)

### 7.5.2 I2C master write, slave read

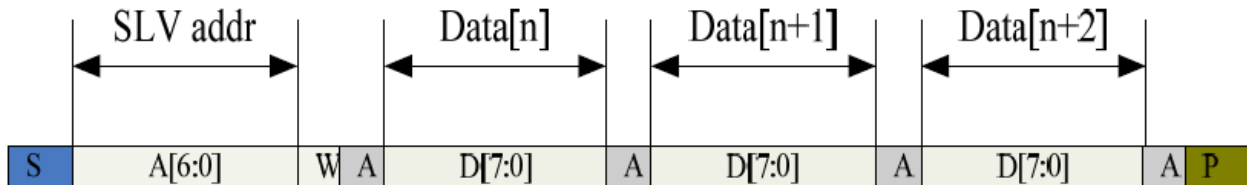

### 7.5.3 I2C master read, slave write

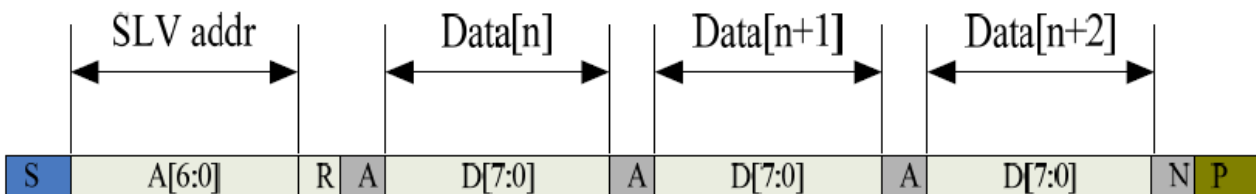

Mnemonics	Description
S	I2C Start or I2C Restart
A[6:0]	Slave address A[6:4]: 3'b011 A[3:0]: data bits are identical to those of I2CCON[7:4] register.
W	1'b0: Write
R	1'b1: Read
A(N)	ACK(NACK)
P	STOP: the indication of the end of a packet (if this bit is missing, S will indicate the end of the current packet and the beginning of the next packet)

### 7.6 Register Definitions

Address	Name	Bit7	Bit6	Bit5	Bit4	Bit3	Bit2	Bit1	Bit0	Host Access	
00h	DEVIDE_MODE	Device Mode[2:0]									RW
01h	GEST_ID	Gesture ID[7:0]								R	
02h	TD_STATUS					Number of touch points[3:0]				R	
03h	TOUCH1_XH	1 <sup>st</sup> Event Flag				1 <sup>st</sup> Touch X Position[11:8]				R	
04h	TOUCH1_XL	1 <sup>st</sup> Touch X Position[7:0]								R	
05h	TOUCH1_YH	1 <sup>st</sup> Touch ID[3:0]				1 <sup>st</sup> Touch Y Position[11:8]				R	
06h	TOUCH1_YL	1 <sup>st</sup> Touch Y Position[7:0]								R	
07h											
08h											
09h	TOUCH2_XH	2 <sup>nd</sup> Event Flag				2 <sup>nd</sup> Touch X Position[11:8]				R	
0Ah	TOUCH2_XL	2 <sup>nd</sup> touch X Position[7:0]								R	
0Bh	TOUCH2_YH	2 <sup>nd</sup> Touch ID[3:0]				2 <sup>nd</sup> Touch Y Position[11:8]				R	
0Ch	TOUCH2_YL	2 <sup>nd</sup> Touch Y Position[7:0]								R	
0Dh											
0Eh											
0Fh	TOUCH3_XH	3 <sup>rd</sup> Event Flag				3 <sup>rd</sup> Touch X Position[11:8]				R	
10h	TOUCH3_XL	3 <sup>rd</sup> Touch X Position[7:0]								R	
11h	TOUCH3_YH	3 <sup>rd</sup> Touch ID[3:0]				3 <sup>rd</sup> Touch Y Position[11:8]				R	
12h	TOUCH3_YL	3 <sup>rd</sup> Touch Y Position[7:0]								R	
13h											
14h											

15h	TOUCH4_XH	4 <sup>th</sup> Event Flag		4 <sup>th</sup> Touch X Position[11:8]	R
16h	TOUCH4_XL	4 <sup>th</sup> Touch X Position[7:0]			R
17h	TOUCH4_YH	4 <sup>th</sup> Touch ID[3:0]		4 <sup>th</sup> Touch Y Position[11:8]	R
18h	TOUCH4_YL	4 <sup>th</sup> Touch Y Position[7:0]			R
19h					R
1Ah					R
1Bh	TOUCH5_XH	5 <sup>th</sup> Event Flag		5 <sup>th</sup> Touch X Position[11:8]	R
1Ch	TOUCH5_XL	5 <sup>th</sup> Touch X Position[7:0]			R
1Dh	TOUCH5_YH	5 <sup>th</sup> Touch ID[3:0]		5 <sup>th</sup> Touch Y Position[11:8]	R
1Eh	TOUCH5_YL	5 <sup>th</sup> Touch Y Position[7:0]			R
1Fh					R
20h					R
21h	TOUCH6_XH	6 <sup>th</sup> Event Flag		6 <sup>th</sup> Touch X Position[11:8]	
22h	TOUCH6_XL	6 <sup>th</sup> Touch X Position[7:0]			
23h	TOUCH6_YH	6 <sup>th</sup> Touch ID[3:0]		6 <sup>th</sup> Touch Y Position[11:8]	
24h	TOUCH6_YL	6 <sup>th</sup> Touch Y Position[7:0]			
25h					
26h					
27h	TOUCH7_XH	7 <sup>th</sup> Event Flag		7 <sup>th</sup> Touch X Position[11:8]	
28h	TOUCH7_XL	7 <sup>th</sup> Touch X Position[7:0]			
29h	TOUCH7_YH	7 <sup>th</sup> Touch ID[3:0]		7 <sup>th</sup> Touch Y Position[11:8]	
2Ah	TOUCH7_YL	7 <sup>th</sup> Touch Y Position[7:0]			
2Bh					
2Ch					
2Dh	TOUCH8_XH	8 <sup>th</sup> Event Flag		8 <sup>th</sup> Touch X Position[11:8]	
2Eh	TOUCH8_XL	8 <sup>th</sup> Touch X Position[7:0]			
2Fh	TOUCH8_YH	8 <sup>th</sup> Touch ID[3:0]		8 <sup>th</sup> Touch Y Position[11:8]	
30h	TOUCH8_YL	8 <sup>th</sup> Touch Y Position[7:0]			
31h					
32h					

33h	TOUCH9_XH	9 <sup>th</sup> Event Flag		9 <sup>th</sup> Touch X Position[11:8]	
34h	TOUCH9_XL	9 <sup>th</sup> Touch X Position[7:0]			
35h	TOUCH9_YH	9 <sup>th</sup> Touch ID[3:0]		9 <sup>th</sup> Touch Y Position[11:8]	
36h	TOUCH9_YL	9 <sup>th</sup> Touch Y Position[7:0]			
37h					
38h					
39h	TOUCH10_XH	10 <sup>th</sup> Event Flag		10 <sup>th</sup> Touch X Position[11:8]	
3Ah	TOUCH10_XL	10 <sup>th</sup> Touch X Position[7:0]			
3Bh	TOUCH10_YH	10 <sup>th</sup> Touch ID[3:0]		10 <sup>th</sup> Touch Y Position[11:8]	
3Ch	TOUCH10_YL	10 <sup>th</sup> Touch Y Position[7:0]			
3Dh					
3Eh					
3Fh	Reserved				
...	...				
7Fh	Reserved				
80h	ID_G_THGROUP	valid touching detect threshold.			R/W
81h	ID_G_THPEAK	valid touching peak detect threshold.			R/W
82h	ID_G_THCAL	the threshold when calculating the focus of touching.			R/W
83h	ID_G_THWATER	the threshold when there is surface water.			R/W
84h	ID_G_THTEMP	the threshold of temperature compensation.			R/W
85h					R/W
86h	ID_G_CTRL			Power control mode[1:0]	R/W
87h	ID_G_TIME_ENTER_MONITOR	The timer of entering monitor status			R/W
88h	ID_G_PERIODACTIVE			Period Active[3:0]	R/W
89h	ID_G_PERIODMONITOR	The timer of entering idle while in monitor status			R/W
8Ah					R/W
8Bh					R/W
8Ch					R/W
8Dh					R/W
8Eh					R/W
8Fh					R/W
90h					R/W

91h			R/W
92h			R/W
93h			R/W
94h			R/W
95h			R/W
96h			R/W
97h			R/W
98h			R/W
99h			R/W
9Ah			R/W
9Bh			R/W
9Ch			R/W
9Dh			R/W
9Eh			R/W
9Fh			R/W
A0h	ID_G_AUTO_CLB_MODE	auto calibration mode	R/W
A1h	ID_G_LIB_VERSION_H	Firmware Library Version H byte	R
A2h	ID_G_LIB_VERSION_L	Firmware Library Version L byte	R
A3h	ID_G_CIPHER	Chip vendor ID	R
A4h	ID_G_MODE	the interrupt status to host	R
A5h	ID_G_PMODE	Power Consume Mode	
A6h	ID_G_FIRMID	Firmware ID	R
A7h	ID_G_STATE	Running State	
A8h	ID_G_FT5201ID	CTPM Vendor ID	R
A9h	ID_G_ERR	Error Code	R
AAh	ID_G_CLB	Configure TP module during calibration in Test Mode	R/W
ABh			R/W
ACh			R/W
ADh			R/W
AEh	ID_G_B_AREA_TH	The threshold of big area	R/W
AFh			R/W
...	...		
FDh	Reserved		
FEh	LOG_MSG_CNT	The log MSG count	R
FFh	LOG_CUR_CHA	Current character of log message, will point to the next character when one character is read.	R

8. OPTICAL CHARACTERISTICS

Item	Symbol	Condition	Min.	Typ.	Max.	Unit
Brightness	--	Note1, Note 3, ( $\theta = 0^\circ$ ; Normal Viewing Angle)	800	1000	--	cd/m <sup>2</sup>
Uniformity	B-uni		70	75	-	%
Contrast Ratio	CR		640	800	--	--
Response Time	Tr + Tf		--	30	40	ms
Color Chromaticity	White	Wx	0.260	0.310	0.360	--
		Wy	0.280	0.330	0.380	--
View angle	Horizontal	$\theta x+$	70	80	--	
		$\theta x-$	70	80	--	
	Vertical	$\theta Y+$	70	80	--	
		$\theta Y-$	70	80	--	

Note : The following optical specifications shall be measured in a darkroom or equivalent state(ambient luminance  $\leq 1$  lux, and at room temperature). The operation temperature is  $25^\circ\text{C} \pm 2^\circ\text{C}$ . The measurement method is shown in Note1.

Note1: The method of optical measurement:

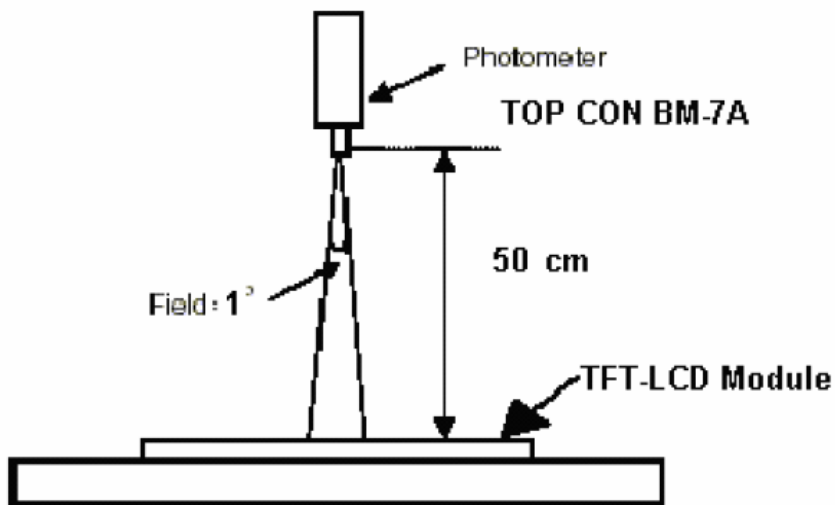

Note2: Measured at the center area of the panel and at the viewing angle of the  $\theta x = \theta y = 0^\circ$

Note3: Definition of Contrast Ratio (CR):

CR = Luminance with all pixels in white state  $\div$  Luminance with all pixels in Black state

Note 4: Definition of Viewing Angle:

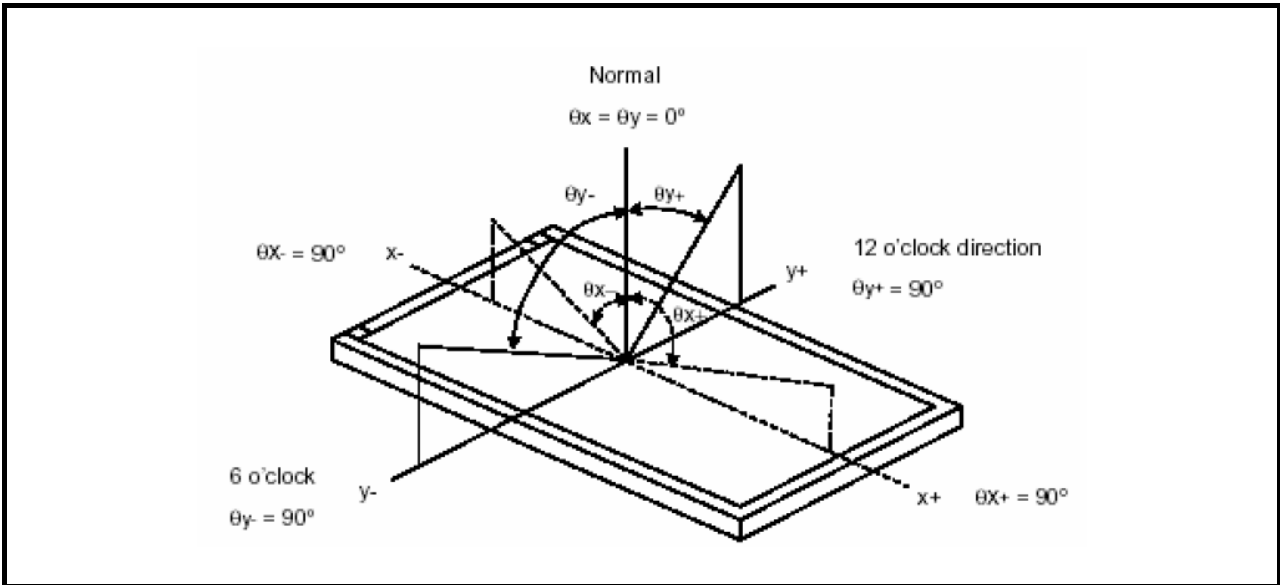

Note 5: Definition of Brightness Uniformity (B-uni):

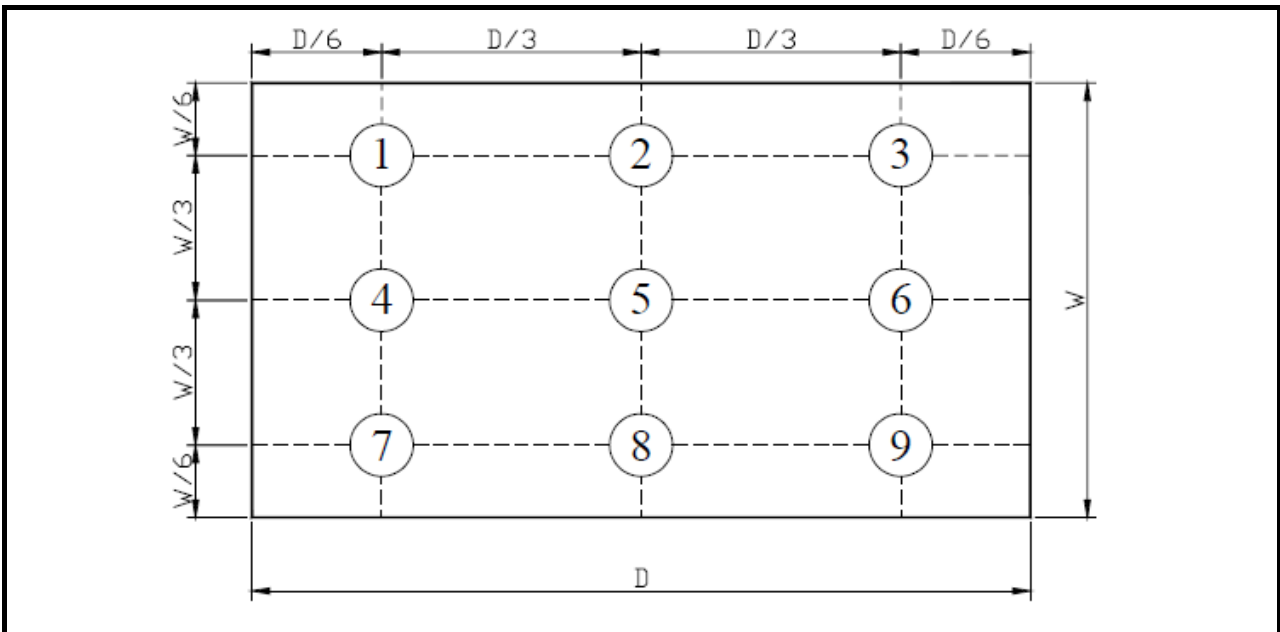

$$B\text{-uni} = (\text{Minimum luminance of 9 points} \div \text{Maximum luminance of 9 points}) \times 100\%$$

**Note 6: Definition of Response Time:**

The Response Time is set initially by defining the “Rising Time (Tr)” and the “Falling Time (Tf)” respectively. Tr and Tf are defined as following figure

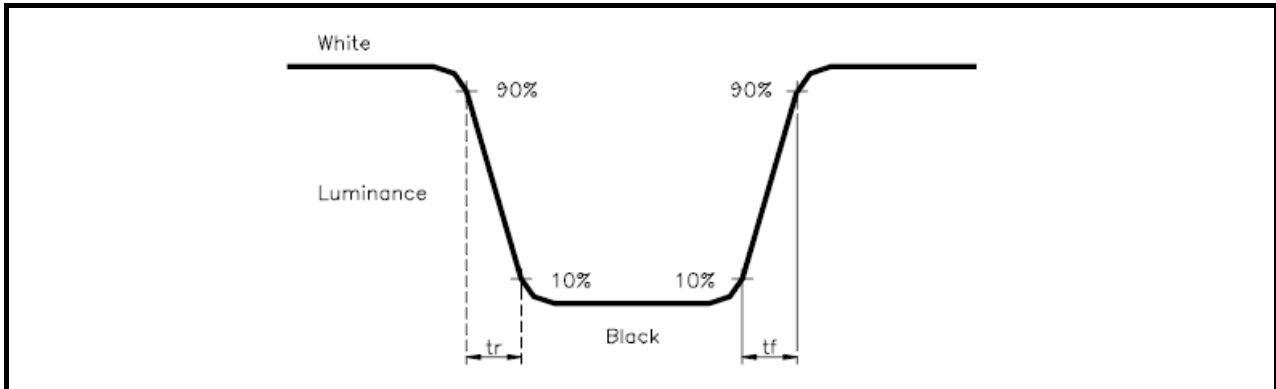

**Note 7: Definition of Chromaticity:**

The color coordinates (Wx,Wy),(Rx,Ry),(Gx,Gy),and (Bx,By) are obtained with all pixels in the viewing field at white, red, green, and blue states, respectively.

**9. RELIABILITY**

**9.1 Test Condition**

**9.1.1 Temperature and Humidity(Ambient Temperature)**

Temperature : 25 ± 5°C

Humidity : 65 ± 5%

**9.1.2 Operation**

Unless specified otherwise, test will be conducted under function state.

**9.1.3 Container**

Unless specified otherwise, vibration test will be conducted to the product itself without putting it in a container.

**9.1.4 Test Frequency**

In case of related to deterioration such as shock test. It will be conducted only once.

**9.2 TESTS**

No.	ITEM	CONDITION CRITERION
1	High Temperature Storage	80°C, 120 hrs
2	Low Temperature Storage	-30°C, 120 hrs
3	High Temperature Operating	70°C, 120 hrs
4	Low Temperature Operating	-30°C, 120 hrs
5	High Temperature/Humidity Non-Operating	40°C, 90%RH, 120 hrs
6	Temperature Shock Non-Operating	-30°C ↔ 80°C (0.5hr each), 100 cycles
7	Vibration Test Non-Operating	Frequency:0 ~ 55 Hz Amplitude:1.5 mm Sweep Time:11min Test Period:6 Cycles for each Direction of X,Y,Z
8	Electro-static Discharge	± 2KV, Human Body Mode, 100pF/1500Ω

Note1: The test sample have recovery time for 24 hours at room temperature before the function check. In the standard conditions, there is no any touch panel function NG issue occurred.

### 9.3 JUDGMENT STANDARD

The judgment of the above test should be made as follow:

Pass: Normal display image with no obvious non-uniformity and no line defect. Partial transformation of the module parts should be ignored.

Fail: No display image, obvious non-uniformity, or line defects.

9.4 INCOMING INSPECTION STANDARDS

No.	Parameter	Criteria														
1	Operating	Display function: No Display malfunction (Major)														
		Contrast ratio (Black, White): Does not meet specified range in the spec. (Major) (Note:3)														
		Line Defect: No obvious Vertical and Horizontal line defect in bright, dark and colored. (Major) (Note:1)														
		Point Defect : Active area $\leq 5$ dots (Minor) (Note:1)														
		<table border="1"> <thead> <tr> <th rowspan="2">Item</th> <th>Acceptable number</th> <th rowspan="2">Total</th> </tr> <tr> <th>Active Area</th> </tr> </thead> <tbody> <tr> <td>Bright</td> <td>2</td> <td rowspan="2">5</td> </tr> <tr> <td>Dark</td> <td>4</td> </tr> </tbody> </table>	Item	Acceptable number	Total	Active Area	Bright	2	5	Dark	4					
Item	Acceptable number	Total														
	Active Area															
Bright	2	5														
Dark	4															
2	External Inspection (non-operating)	Non-uniformity: Visible through 5%ND filter. (Minor)														
		Foreign material in Black or White spots shape ( $W > 1/4L$ )														
		<table border="1"> <thead> <tr> <th>Zone Dimension</th> <th>Acceptable number</th> <th rowspan="3">Class Of Defects</th> <th rowspan="3">AQL Level</th> </tr> </thead> <tbody> <tr> <td><math>D &gt; 0.5</math></td> <td>0</td> </tr> <tr> <td><math>0.3 &lt; D \leq 0.5</math></td> <td>5</td> </tr> <tr> <td><math>D \leq 0.3</math></td> <td>*</td> <td>Minor</td> <td>1.5</td> </tr> </tbody> </table> <p><math>D = (\text{Long} + \text{Short}) / 2</math> * : Disregard</p>	Zone Dimension	Acceptable number	Class Of Defects	AQL Level	$D > 0.5$	0	$0.3 < D \leq 0.5$	5	$D \leq 0.3$	*	Minor	1.5		
		Zone Dimension	Acceptable number	Class Of Defects			AQL Level									
		$D > 0.5$	0													
$0.3 < D \leq 0.5$	5															
$D \leq 0.3$	*	Minor	1.5													
Foreign Material in Line or spiral shape ( $W \leq 1/4L$ ) (Note: 4)																
<table border="1"> <thead> <tr> <th>L (mm)</th> <th>Zone W(mm)</th> <th>Acceptable number</th> <th rowspan="3">Class Of Defects</th> <th rowspan="3">AQL Level</th> </tr> </thead> <tbody> <tr> <td><math>L &gt; 5</math></td> <td><math>W &gt; 0.1</math></td> <td>0</td> </tr> <tr> <td><math>0.5 &lt; L \leq 5</math></td> <td><math>0.03 &lt; W \leq 0.1</math></td> <td>5</td> </tr> <tr> <td><math>L \leq 0.5</math></td> <td><math>W \leq 0.03</math></td> <td>*</td> <td>Minor</td> <td>1.5</td> </tr> </tbody> </table> <p>L : Length W : Width * : Disregard</p>	L (mm)	Zone W(mm)	Acceptable number	Class Of Defects	AQL Level	$L > 5$	$W > 0.1$	0	$0.5 < L \leq 5$	$0.03 < W \leq 0.1$	5	$L \leq 0.5$	$W \leq 0.03$	*	Minor	1.5
L (mm)	Zone W(mm)	Acceptable number	Class Of Defects			AQL Level										
$L > 5$	$W > 0.1$	0														
$0.5 < L \leq 5$	$0.03 < W \leq 0.1$	5														
$L \leq 0.5$	$W \leq 0.03$	*	Minor	1.5												
2	External Inspection (non-operating)	Dimension: Outline (Major)														
		Bezel appearance: uneven (Minor)														
		Scratch on the polarize: (Note:2)														
		<table border="1"> <thead> <tr> <th>L (mm)</th> <th>Zone W(mm)</th> <th>Acceptable number</th> <th rowspan="2">Class Of Defects</th> <th rowspan="2">AQL Level</th> </tr> </thead> <tbody> <tr> <td>--</td> <td><math>W &gt; 0.1</math></td> <td>0</td> </tr> <tr> <td><math>L \leq 3</math></td> <td><math>W \leq 0.1</math></td> <td>3</td> <td>Minor</td> <td>1.5</td> </tr> </tbody> </table> <p>L : Length W : Width * : Disregard</p>	L (mm)	Zone W(mm)	Acceptable number	Class Of Defects	AQL Level	--	$W > 0.1$	0	$L \leq 3$	$W \leq 0.1$	3	Minor	1.5	
		L (mm)	Zone W(mm)	Acceptable number	Class Of Defects			AQL Level								
--	$W > 0.1$	0														
$L \leq 3$	$W \leq 0.1$	3	Minor	1.5												
Dent or bubble on the polarize (Note:2)																
<table border="1"> <thead> <tr> <th>Zone Dimension</th> <th>Acceptable number</th> <th rowspan="2">Class Of Defects</th> <th rowspan="2">AQL Level</th> </tr> </thead> <tbody> <tr> <td><math>D \leq 0.3</math></td> <td>*</td> </tr> <tr> <td><math>D \leq 0.5</math></td> <td>3</td> <td>Minor</td> <td>1.5</td> </tr> </tbody> </table> <p><math>D = (\text{Long} + \text{Short}) / 2</math> * : Disregard</p>	Zone Dimension	Acceptable number	Class Of Defects	AQL Level	$D \leq 0.3$	*	$D \leq 0.5$	3	Minor	1.5						
Zone Dimension	Acceptable number	Class Of Defects			AQL Level											
$D \leq 0.3$	*															
$D \leq 0.5$	3	Minor	1.5													

Class of defects			Definition
	<b>Major</b>	AQL 0.65%	
<b>Minor</b>	AQL 1.5%		It is a defect that will not result in functioning problem with deviation classified.

Note1:

- (a) Bright point defect is defined as point defect of R,G,B with area  $> 1/2$  pixel respectively
- (b) Dark point defect is defined as visible in full white pattern.
- (c) Definition of distribution of point defect is as follows:
  - minimum separation between dark point defects should be larger than 5mm.
  - minimum separation between bright point defects should be larger than 5mm.
- (d) Definition of joined bright point defect and joined dark point defect are as follows:
  - Two or more joined bright point defects must be nil.
  - Three joined dark point defects must be nil.
  - Coupling of one dark and one bright point in junction is counted as one dark and bright spot with 1 pair maximum.
  - Two Joined dark point is counted as two dark points with 2 pair maximum.

Note2: The external inspection should be conducted at the distance  $30 \pm 5$ cm between the eyes of inspector and the panel.

Note3: Luminance measurement for contrast ratio is at the distance  $50 \pm 5$ cm between the detective head and the panel with ambient luminance less than 1 lux. Contrast ratio is obtained at optimum view angle.

Note4: W-Width in mm , L-length of Max.(L1,L2) in mm.

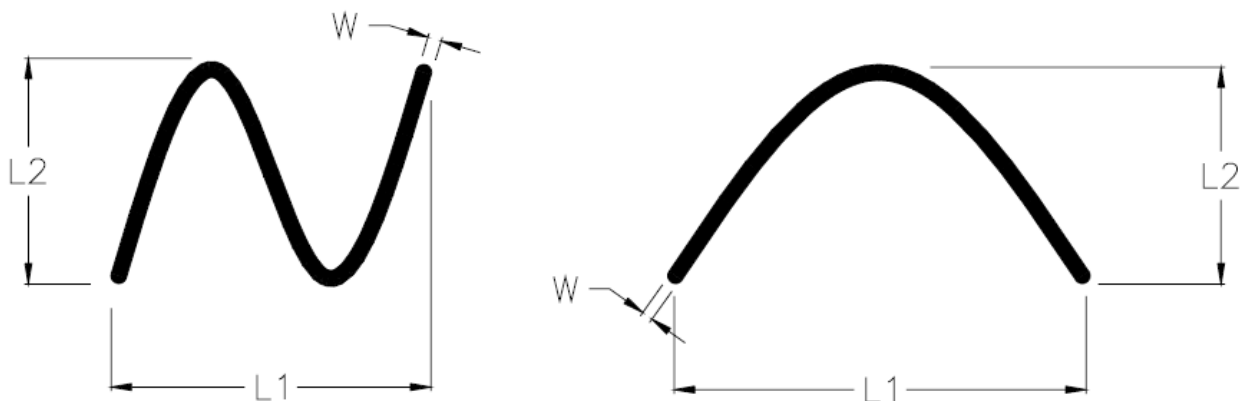

### 9.5 Sampling Condition

Unless otherwise agree in written, the sampling inspection shall be applied to the incoming inspection of customer.

Lot size: Quantity of shipment lot per model.

Sampling type: normal inspection, single sampling

Sampling table: MIL-STD-105E

Inspection level: Level II

### 9.6 Inspection conditions

The LCD shall be inspected under 40W white fluorescent light.

$\theta \leq 45^\circ$  inspection under non-operating condition.

$\theta \leq 5^\circ$  inspection under operating condition

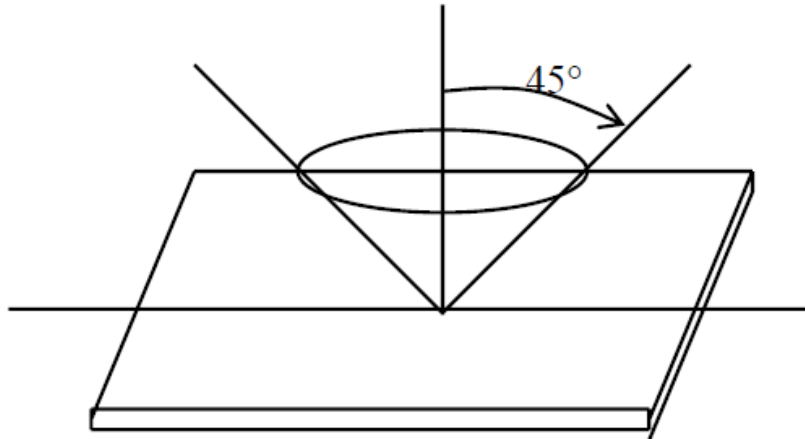

## **10. PRECAUTION RELATING PRODUCT HANDLING**

### **10.1 SAFETY**

**10.1.1** If the LCD panel breaks , be careful not to get the liquid crystal to touch your skin.

**10.1.2** If the liquid crystal touches your skin or clothes , please wash it off immediately by using soap and water.

### **10.2 HANDLING**

**10.2.1** Avoid any strong mechanical shock which can break the glass.

**10.2.2** Avoid static electricity which can damage the CMOS LSI—When working with the module, be sure to ground your body and any electrical equipment you may be using.

**10.2.3** Do not remove the panel or frame from the module.

**10.2.4** The polarizing plate of the display is very fragile. So , please handle it very carefully, Do not touch, push or rub the exposed polarizing with anything harder than an HB pencil lead (glass , tweezers , etc.)

**10.2.5** Do not wipe the polarizing plate with a dry cloth, as it may easily scratch the surface of plate.

**10.2.6** Do not touch the display area with bare hands , this will stain the display area.

**10.2.7** Do not use ketonics solvent & aromatic solvent. Use with a soft cloth soaked with a cleaning naphtha solvent.

**10.2.8** To control temperature and time of soldering is  $280 \pm 10^{\circ}\text{C}$  and 3-5 sec.

**10.2.9** To avoid liquid (include organic solvent) stained on LCM.

### **10.3 STORAGE**

**10.3.1** Store the panel or module in a dark place where the temperature is  $25^{\circ}\text{C} \pm 5^{\circ}\text{C}$  and the humidity is below 65% RH.

**10.3.2** Do not place the module near organics solvents or corrosive gases.

**10.3.3** Do not crush, shake, or jolt the module.

## The Netherlands



Elektrostraat 17  
NL-7483 PG Haaksbergen

T: +31 (0)53 573 33 33  
F: +31 (0)53 573 33 30  
E: [nl@texim-europe.com](mailto:nl@texim-europe.com)

## Belgium



Zuiderlaan 14 bus 10  
B-1731 Zellik

T: +32 (0)2 462 01 00  
F: +32 (0)2 462 01 25  
E: [belgium@texim-europe.com](mailto:belgium@texim-europe.com)

## UK & Ireland



St. Mary's House, Church Lane  
Carlton Le Moorland  
Lincoln LN5 9HS

T: +44 (0)1522 789 555  
F: +44 (0)845 299 22 26  
E: [uk@texim-europe.com](mailto:uk@texim-europe.com)

## Germany North



Bahnhofstrasse 92  
D-25451 Quickborn

T: +49 (0)4106 627 07-0  
F: +49 (0)4106 627 07-20  
E: [germany@texim-europe.com](mailto:germany@texim-europe.com)

## Germany South



Martin-Kollar-Strasse 9  
D-81829 München

T: +49 (0)89 436 086-0  
F: +49 (0)89 436 086-19  
E: [germany@texim-europe.com](mailto:germany@texim-europe.com)

## Austria



Warwitzstrasse 9  
A-5020 Salzburg

T: +43 (0)662 216 026  
F: +43 (0)662 216 026-66  
E: [austria@texim-europe.com](mailto:austria@texim-europe.com)

## Nordic region



Sdr. Jagtvej 12  
DK-2970 Hørsholm

T: +45 88 20 26 30  
F: +45 88 20 26 39  
E: [nordic@texim-europe.com](mailto:nordic@texim-europe.com)

## Italy



Via Matteotti 43  
IT-20864 Agrate Brianza (MB)

T: +39 (0)39 971 3293  
F: +39 (0)39 971 3293  
E: [italy@texim-europe.com](mailto:italy@texim-europe.com)

## General information



[info@texim-europe.com](mailto:info@texim-europe.com)  
[www.texim-europe.com](http://www.texim-europe.com)